

NEWALL NEWALL MEASUREMENT SYSTEMS LTD

SHG & MHG Incremental Linear Encoders

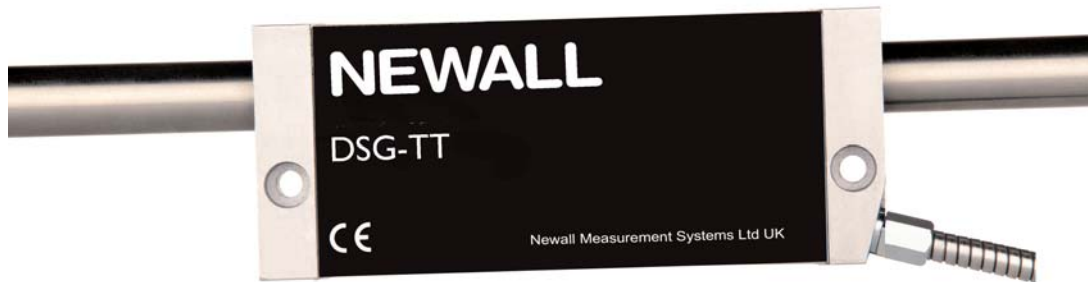

For models

SHG-TT

SHG-PV

SHG-VP

SHG-VV

SHG-VM

MHG-TT

MHG-VP

MHG-VV

MHG-VM

CONTENTS

1.0 Technical Specification

- 1.1 Bracketry
- 1.2 Preparation
- 1.3 Warnings

2.0 Technical Specification

- 2.1 Cable Connections
- 2.2 Index Marker Synchronisation
- 2.3 Resolution Option
- 2.4 Maximum Traverse Rates
- 2.5 Recommended Encoder Connections

3.0 SHG Encoder Assembly

4.0 MHG Encoder Assembly

5.0 Mounting The Reader Head

- 5.1 SHG
- 5.2 MHG

6.0 Mounting The Scale

- 6.1 SHG
 - 6.1.1 Double End Mounting
 - 6.1.2 Single End Mounting
 - 6.1.3 Scales in excess of 2.5 metres
- 6.2 MHG Scale
 - 6.2.1 Single End Mounting

7.0 Fitting The Scale Guard

8.0 Cable Routing

9.0 Final Check

Appendix A

1.0 INTRODUCTION

This manual will provide mounting instructions for Newall's SHG and MHG Incremental Linear Encoders. It is important that you read and understand this manual prior to beginning the installation.

If at any time during the installation you should have any questions, contact Newall or your local authorised representative.

1.1 Bracketry

Due to the variety of machine types and applications, it will be necessary to design, make and fit custom brackets for the encoder assembly. If bracketry is needed make certain they are rigid enough not to allow any flexing or distorting while the machine is in operation. Newall offers a variety of bracket kits to aid in the installation. Contact Newall or your local authorised representative for details.

1.2 Preparation

Prior to beginning the installation the machine should be studied to determine where the Encoder(s) will be fitted.

For best results, it is recommended that the scale be fitted as close to the machine lead screw or axial drive shaft as possible.

The actual overall scale length is approximately 258mm (10.2") for SHG and 187mm (7.4") for MHG longer than the stated scale travel. (e.g. if the travel length is 40" (SHG) the actual overall scale length of the scale will be 50")

Outboard mounting of the scale support brackets will add approximately 20mm (3/4") to the effective scale travel. (Refer to Appendix A)

For a more compact installation, scale travels of 300mm (12") or less may be fitted by supporting one end of the scale only by use of a single end mounting block. (Refer to Figure 5.4 and 5.10)

The moving member of the Encoder assembly can be either the Reader Head or the Scale.

Cable routing from the Reader Head should be examined (See Section 7). Each Reader Head is provided with either a 3.5 metre (11') or 7 metre (22') of armoured cable. Extension cables are available in 1 metre (3'), 2 metre (6'), 3.5 metre (11.5'), 5 metre (16.5') and 10 metre (32') lengths. Contact Newall or your local authorised representative for details.

1.3 Warnings

If for any reason the machine axis travel is greater than the actual scale travel it is recommended that 'mechanical stops' are fitted to the machine to avoid damage caused by over travel.

Both the Reader Head and the Scale are precision made components and it is important that they are handled with care. By design the Encoders can withstand the rigours of the harsh workshop environment. However, permanent damage can occur through bending or severe impact.

It is important that the Scale be kept at least 13mm (0.5") away from any magnetic bases on indicators or magnetic chucks.

2.0 TECHNICAL SPECIFICATIONS

Construction:

Housing	Aluminium
Standard Cable	3.5m (1/4") Fully interlocked Stainless Steel conduit armour 9-way 'D-Type' connector or Flying lead

Dimensions (reader head):

MHG

Height	35.0mm	(1.378")	
Width	75.0mm	(2.953")	
Depth	25.0mm	(0.984")	
Weight	0.640Kg	(1.410lbs)	(max. inc. 3.5m cable)

SHG

Height	53.5mm	(2.106")	
Width	131.0mm	(5.157")	
Depth	28.5mm	(1.112")	
Weight	0.858Kg	(1.890lbs)	(max. inc. 3.5m cable)

Operating Voltage: 5 VDC ± 5% (For SHG-TT,-VV,-VM, MHG-TT,-VV,-VM)

Supply Voltage Fluctuation: Within operating voltage range

Maximum Power Consumption: <80mA

Operating Temperature: 0 to 55oC

Storage Temperature: -20 to 70oC

Outputs (SHG-TT,-VV,-VM, MHG-TT,-VV,-VM): Differential Quadrature with Synchronised Reference mark
Via. RS422 compatible line drivers @ 5V TTL levels

Maximum Output frequency: 2,000,000 counts/sec (500kHz per channel) NA for SHG-VP,MHG-VP

Maximum cable length: 22m (using Newall supplied cables)

Required Moving Force:

MHG	10N
SHG	20N

Scale Type:

MHG	Carbon Fibre	5.64mm OD	(0.222")
SHG	Stainless Steel	15.24mm OD	(0.600")

Environmental Conditions: IP67 (fully submersible) according to IEC529.
Exceeds NEMA Type 6

EMC Compliance:

BS EN 50081-2 Electromagnetic Compatibility
Generic Emission Standard - Industrial Environment
BS EN 50082-2 Electromagnetic Compatibility
Generic Immunity Standard - Industrial Environment



Certificate No FM36096

NOTE: NEWALL MEASUREMENT SYSTEMS LIMITED RESERVES THE RIGHT TO CHANGE THE SPECIFICATION WITHOUT NOTICE

2.1 CABLE CONNECTIONS

The following pinout applies to SHG-TT, SHG-VV, SHG-VM, MHG-TT, MHG-VV, MHG-VM.

Pin	Core	Function	Colour
1	26AWG	N/C (or 0V)	Orange
2	26AWG	Channel A	Green
3	Twisted pair	Channel /A	Yellow
4	26AWG	Channel B	Blue
5	Twisted pair	Channel /B	Red
6	18AWG	0V	White
7	18AWG	5V	Black
8	26AWG	Channel RM	Violet
9	Twisted pair	Channel /RM	Grey
Shell	Overall Braid	Gnd	---

Note: Pin 1 (Orange wire) is used during manufacture and should be either not be connected or tied to 0V. SHG-PV pinout can be found on datasheet 023-80130.

2.2 Index Marker Synchronisation for SHG-TT & MHG-TT

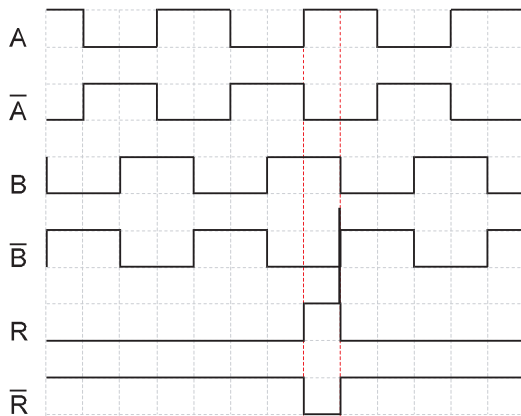

The Index marker pulse is synchronised to the A and B channel High-High states

Encoder Type	Reference Marker Type	Period
SHG	Periodic	12.7mm (1/2")
MHG	Periodic	5mm (0.19685")

2.3 Resolution Options for SHG-TT & MHG-TT

Both SHG-TT and MHG-TT are available, to order, with a range of pre-programmed resolutions as shown below.

Resolution	SHG-TT	MHG-TT	Equivalent Line Count/Inch	Equivalent Grating Period
0.2 μ m	X	√	31,750	0.8 μ m
0.5 μ m	√	√	12,700	2 μ m
1 μ m	√	√	6,350	4 μ m
2 μ m	√	√	3,175	8 μ m
5 μ m	√	√	1,270	20 μ m
10 μ m	√	√	635	40 μ m

In addition to the standard resolution options available, a Developers kit is available for the development of customised resolutions.

2.4 Maximum Traverse Rates

SHG-TT, -VV, -VM, -PV, and MHG-TT, -VV, VM encoders have a maximum output rate of 2MHz.

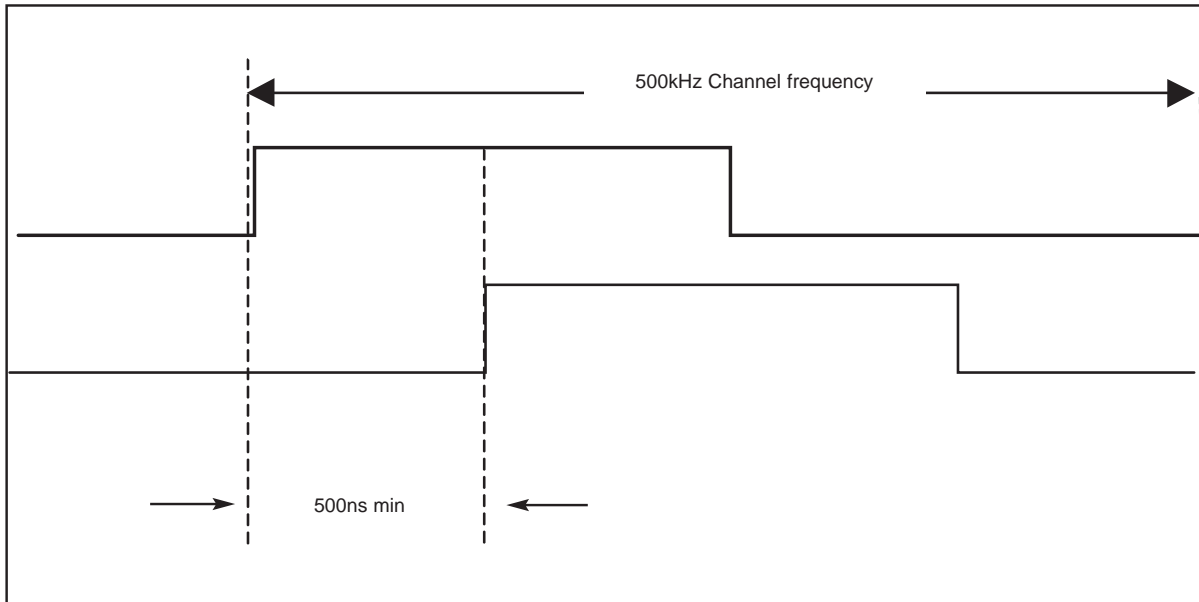

As a result, the maximum speed for a given encoder is proportional to the resolution at which it is operating.

Resolution	Traverse Speed (m/s)	
	SHG-TT	MHG-TT
0.2µm	N/A	0.4
0.5µm	1.0	1.0
1µm	2.0	2.0
2µm	4.0	4.0
5µm	10.0	10.0
10µm	20.0	20.0

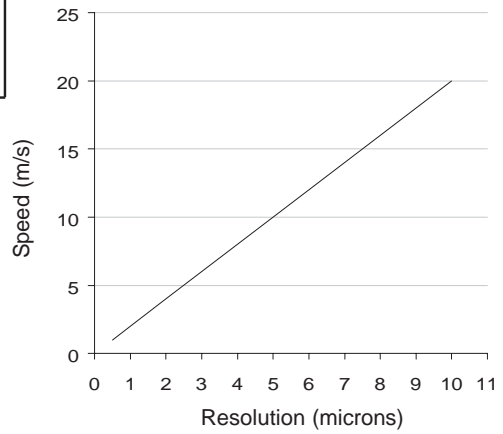

2.5 Recommended Encoder Connections

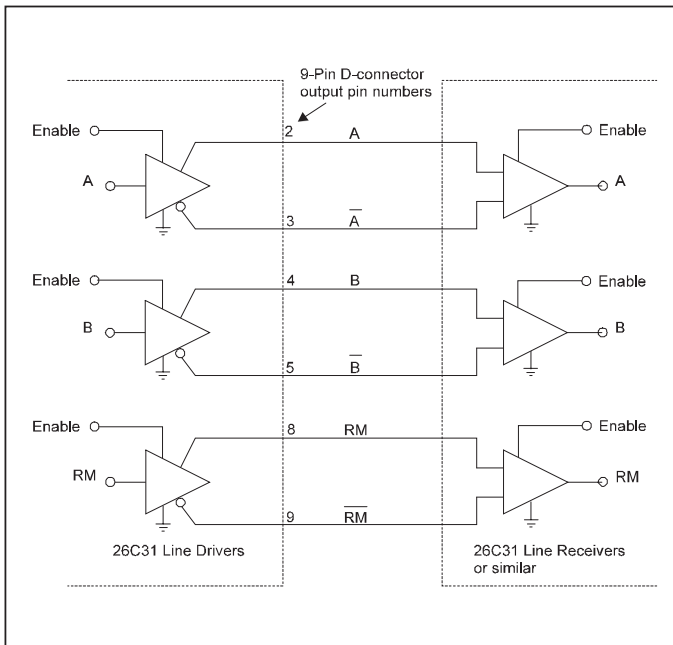

SHG-TT and MHG-TT provide differential quadrature outputs at RS422 TTL levels.

Note. The copper screen should always be tied to ground.

3.0 SHG ENCODER ASSEMBLY

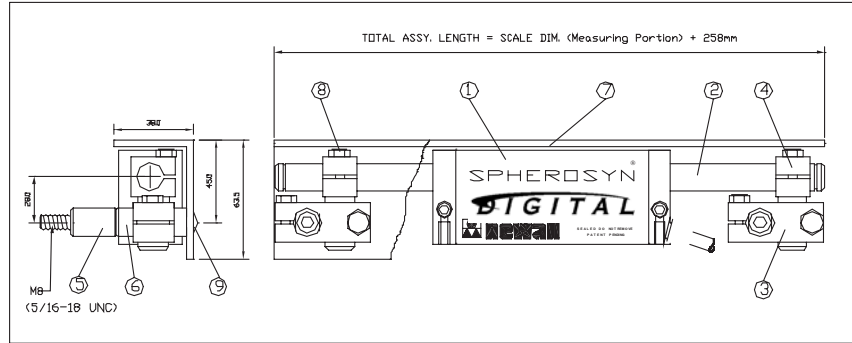

Item	Description	Qty	Item	Description	Qty
1	SHG Reader Head	1	6	Support Pillar Long	2
2	SHG Scale	1	7	Scale Cover	1
3	Scale Support Link	2	8	M5 x 20 Hex Head	6
4	Scale Anchor Pin	2	9	M8 x Socket Button Head	2
5	Support Pillar Short	2			

4.0 MHG ENCODER ASSEMBLY

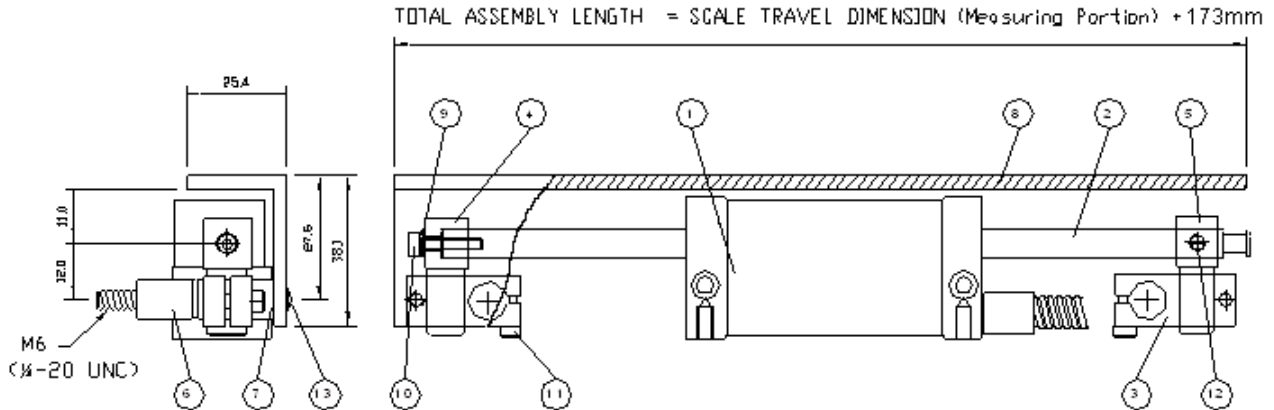

Item	Description	Qty	Item	Description	Qty
1	MHG Reader Head	1	8	Scale Cover	1
2	MHG Scale	1	9	M3 Spring Washer	1
3	Support Link	2	10	M3 x 16 SHCS	1
4	Anchor Pin	1	11	M3 x 12 SHCS	4
5	Support Pin	1	12	M4 x 5 Nylon Set Screw	1
6	Support Pillar Short	2	13	M6 x 10 Socket Button Head	2
7	Support Pillar Long	2			

5.0 MOUNTING THE DIGITAL READER HEAD

5.1 SHG

Mount the Reader Head together with its bracket(s) to the machine and secure the assembly parallel with axis travel to within $\pm 0.05\text{mm}$ (0.002"). (Refer to Figure 5.1)

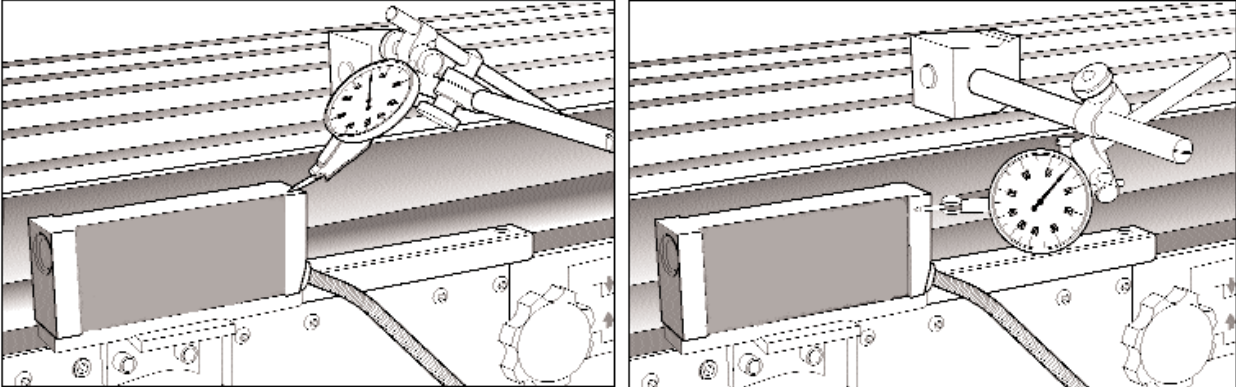

Figure 5.1 - Alignment of the SHG Reader Head

Final adjustments can be carried out by use of laminated shims, which are included with each transducer assembly. Each layer of shim is equivalent to 0.05mm (0.002").

5.2 MHG

Mount the Reader Head together with its bracket(s) to the machine and secure the assembly parallel with axis travel to within $\pm 0.05\text{mm}$ (0.002"). (Refer to Figure 5.2)

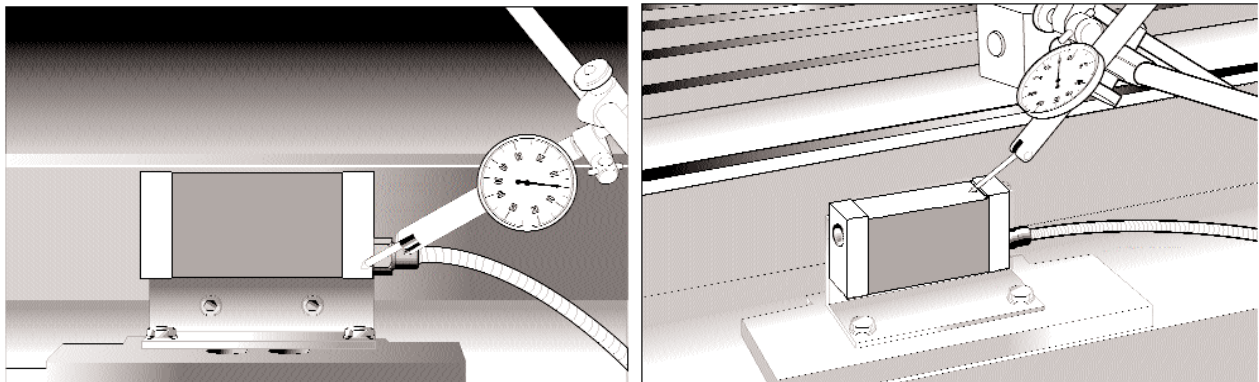

Figure 5.2 - Alignment of the MHG Reader Head

6.0 MOUNTING THE SCALE

6.1 SHG

6.1.1 Double End Mounting

Note: Refer to section 6.1.3 for mounting scales in excess of 2.5 metres.

Each end of the SHG Scale is different and can be identified by the pan head screw at the 'tensioner end' and a nylon snap rivet at the 'fixed end'.

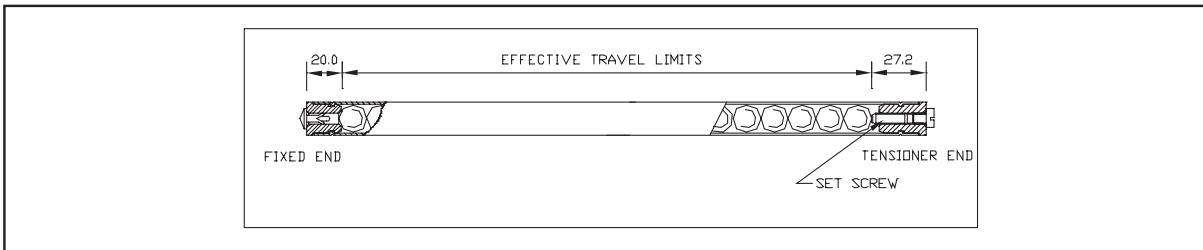

NOTES:

- (A) Erroneous readings will occur if the Reader Head is allowed to travel beyond the Effective Travel Limits. (Refer to Figure 6.1)
- (B) The pre-load on the balls are factory set via the set screw at the tensioner end. Do not tamper with or adjust the set screw as this will alter the calibration and accuracy specification of the scale. (Refer to Figure 6.1)

Once the Reader Head is secured and correctly aligned, the scale support brackets can now be fitted. The scale support brackets consist of the support pin, the support link and the pillar(s).

Traverse the machine to its maximum position toward the non-cable entry side of the Reader Head. Maximum position means all available travel, including hand winding past any electrical limits or trip dogs.

Carefully slide the SHG setup tube (or SHG scale if less than 60" travel) through the Reader Head, allowing for a sufficient amount of scale to project from the Reader Head in order to fit the scale support brackets.

Assemble the scale support link to the scale support pin leaving approximately 3mm (1/8") gap between the bottom of the pin shoulder and the top of the link.

Slide the link/pin assembly onto the scale to approximately 5mm (0.2") away from the end of the Reader Head.

Transfer punch through the support link and into the machine casting. It is important that the support link is kept square to its mounting surface at all times.

Remove the link/pin assembly and the scale from the Reader Head. Drill and tap M8 x 18mm deep (USA 5/16 - 18 x 3/4" deep) into the machine casting as marked by the transfer punch. Fit the pillar(s) to the machine casting by using one of the methods shown in Figure 6.3. The pillar should fit square and flush to the machine surface.

A maximum of two support pillars may be screwed together to allow for sufficient adjustment of the scale. If two pillars are insufficient to enable the scale to be mounted, then additional brackets will be necessary. These brackets must be sufficiently rigid to eliminate any axial movement of the scale.

Loosely fit the support link/pin assembly onto the pillar and pass the scale through the Reader Head and into the support pin. While gently sliding the scale forward and back 25 - 50mm (1" - 2") through the support pin, carefully tighten the hex screws on the support link, ensuring that the scale slides smoothly through the Reader Head and into the support pin. If any interference is detected then fully loosen the hex screws on the support link and repeat this step.

Note: Do not force the Scale through the Support Pin

IMPORTANT WARNING:

THE CENTRE LINE BORE OF THE READER HEAD MUST BE IN DIRECT ALIGNMENT WITH THE CENTRE LINE BORE OF THE SUPPORT PIN. PERMANENT DAMAGE TO SCALE AND/OR ERRONEOUS READER WILL OCCUR IF THIS WARNING IS NOT FOLLOWED. REFER TO FIGURE 6.2

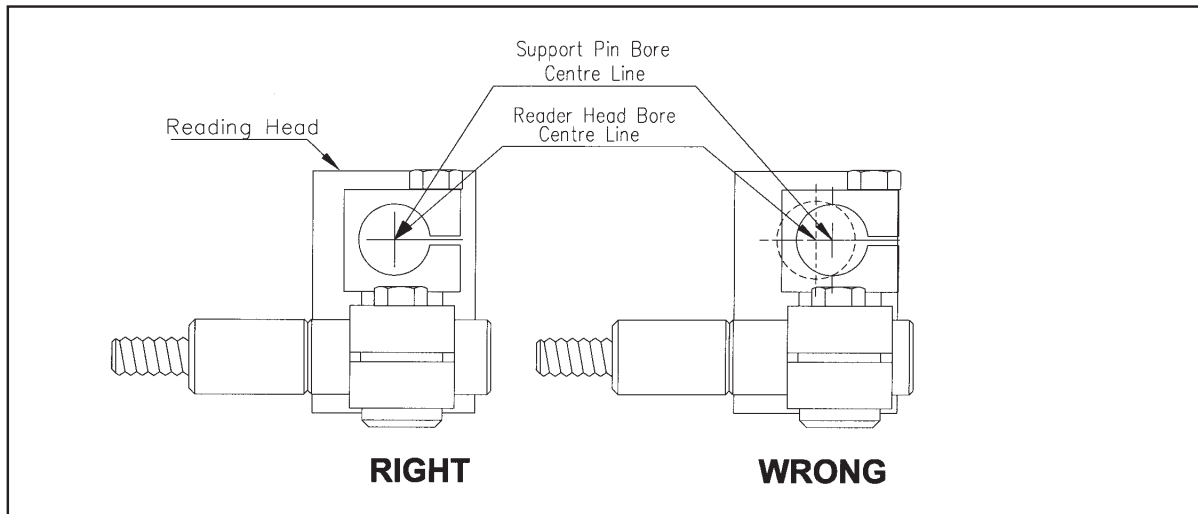

Figure 6.2 - Reader Head and Bracket Alignment

Remove the scale from the Reader Head and traverse the machine to its full extent in the **opposite direction**. Full extent means hand winding past electrical limits.

Assemble the scale support link to the scale support pin leaving approximately 3mm (1/8") gap between the bottom of the pin shoulder and the top of the link.

Slide the link/pin assembly onto the scale making certain that there is sufficient clearance between the Reader Head and the support link to prevent damage to the Reader Head cable. Do not secure the support pin to the scale at this time.

Transfer punch through the support link and into the machine casting. It is important that the support link be kept square to its mounting surface at all times.

Mounting the Scale

Remove the link/pin assembly and the scale from the Reader Head. Drill and tap M8 x 18mm deep (USA 5/16" -18 x 3/4" deep) into the machine casting as marked by the transfer punch. Fit the pillar(s) to the machine casting by using one of the methods shown in figure 6.3. The pillar shoulder fit square and flush to the machine surface.

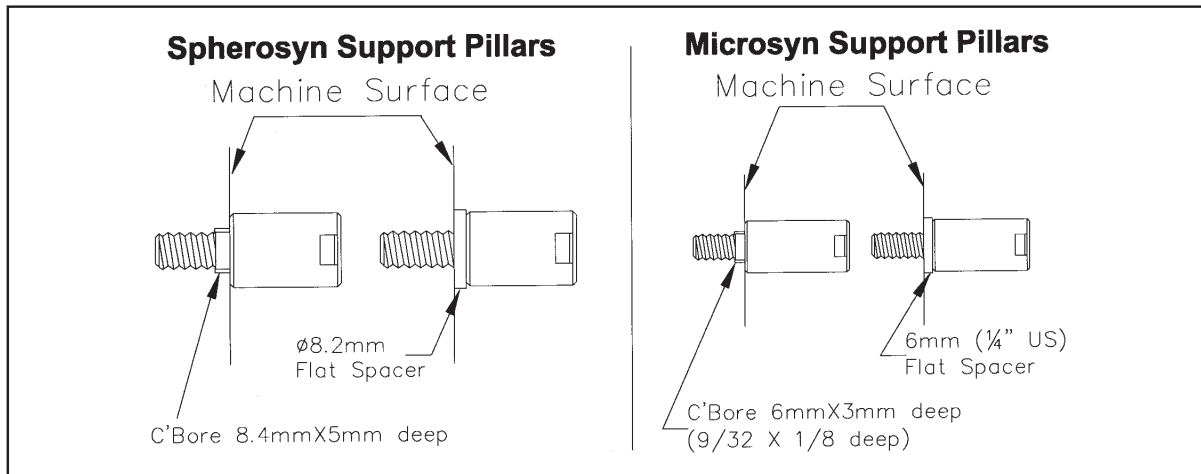

Figure 6.3 - Support Pillars

A maximum of two support pillars may be screwed together to allow for sufficient adjustment of the scale. If two pillars are insufficient to enable the scale to be mounted, then additional brackets will be necessary. These brackets must be sufficiently rigid to eliminate any axial or radial movement of the scale.

Loosely fit the support link/pin assembly onto the pillar and pass the scale through the Reader Head and into the support pin. While gently sliding the scale forward and back 25 - 50mm (1" - 2") through the support pin, carefully tighten the hex screws on the support link, ensuring that the scale slides smoothly through the Reader Head and into the support pin. If any interference is detected then fully loosen the hex screws on the support link and repeat this step.

Carefully slide the SHG Scale through the support pin, through the Reader Head and into the opposite support pin. **FULLY TIGHTEN THE SUPPORT PIN HEX SCREW AT THE FIXED END OF THE SCALE, BUT ONLY 'SNUG UP' THE HEX SCREW ON SUPPORT PIN AT THE TENSIONER END.**

6.1.2 Single End Mounting

Note: The maximum total length of the scale must not exceed 610mm (24") when using a single end mounting kit. The single end mounting kit is sold separately, ask for UK part number 600-63610, USA part number LBK01.

Remove the red cap from the tensioner end of the scale.

After the Reader Head has been installed slide the scale through the Reader Head and insert the tensioner end of the scale into the single end mounting block. (Refer to Figure 6.4)

Once the position for the single end mounting block has been determined mark the machine casting using the slot in the mounting block as the guide. Drill and tap M6 x 12mm deep (USA 1/4 - 20 x 1/2"). Fit the mounting block using the M6 (USA 1/4 - 20) socket head cap screw and washer.

Check the alignment by gently sliding the scale through the head and in and out of the mounting block, adjustments may be carried out by altering the M5 jacking screws. When the alignment is complete secure the scale by inserting the M5 screw and washer through the mounting block and into the tensioner end of the scale.

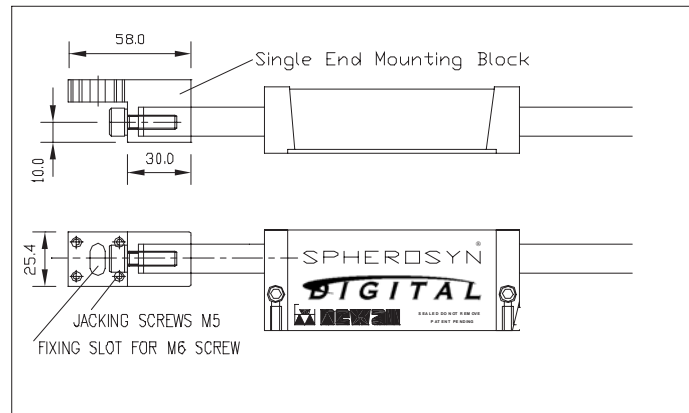

Figure 6.4 - SHG Single End Mounting

6.1.3 Scales in Excess of 2.5 Metres

Traverse the machine to fullest extent of travel including hand winding past any electrical limits or trip dogs.

Insert the short blank length of SHG tube into the Reader Head, allowing for a sufficient amount of scale to project from the Reading Head in order to fit the scale mounting brackets.

Assemble the angle bracket to the scale clamp (Refer to Figure 6.5). The jacking plate is included in each bracket kit, this will only be required if the machine mounting face is not a machined surface. Slide the assembly onto the scale allowing approximately 10mm clearance from the end of the Reader Head.

Mark the position of the jack plate (if required) or the angle support bracket. Drill and tap the necessary fixing holes and assemble the bracket to the machine.

Remove the blank tube and the bracket assembly from the Reader Head. Drill and tap M8 x 18mm (USA 5/16"-18 x 3/4") fixing holes. Fit the jack plate (if required) and secure to the machine. Assemble the scale clamp and the angle bracket to the jack plate but do not secure. Traverse the Reader Head as near to the bracket assembly as possible. Slide the blank tube through the Reader Head into the scale clamp. Adjust the brackets into position and carefully tighten the screws. Check that the blank tube slides through the Reader Head and into the scale clamp smoothly without any fouling or interruption.

Remove the blank tube and traverse the machine to the full extent in the opposite direction. Remember the "full extent" is the absolute maximum travel up to the mechanical "dead stops".

Check the overall length of the actual scale and measure from the outside edge of the scale clamp already fitted to the machine and mark the position of the scale on to the machine.

Slide the SHG blank tube into the Reader Head, assemble the remaining scale bracket assembly including the jacking plate (if required) and slide onto the tube.

Set the outside edge of the scale clamp level with the mark that indicates the overall length of the SHG Scale and mark the fixing position for the bracket assembly.

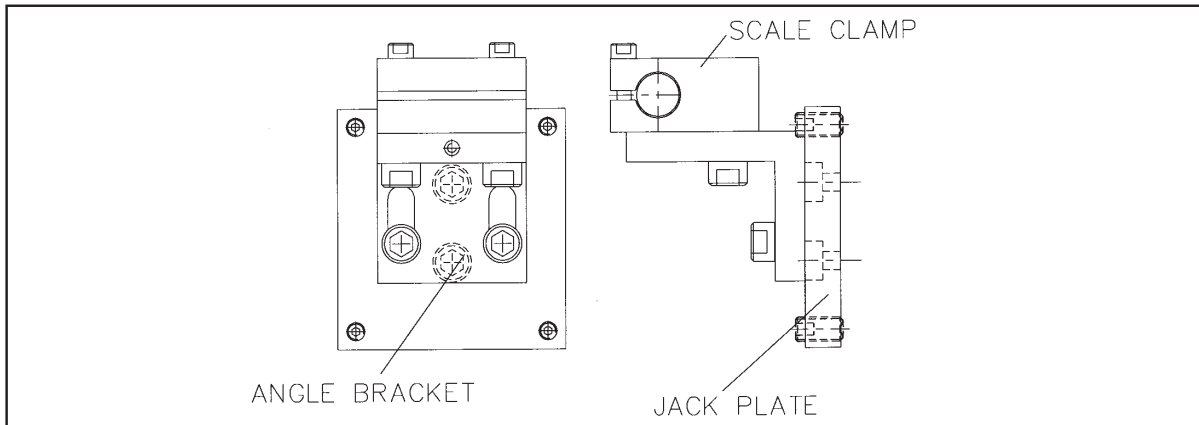

Figure 6.5 - Long Scale Heavy Duty Support Bracket Assembly

6.1.4 Center Supports for scales ≥ 100 " travel

See data sheet supplied with center support kit 600-84600

6.2 MHG Scale

The fixed end of the scale has an M3 tapped hole, which will be fitted to the anchor pin when installed.

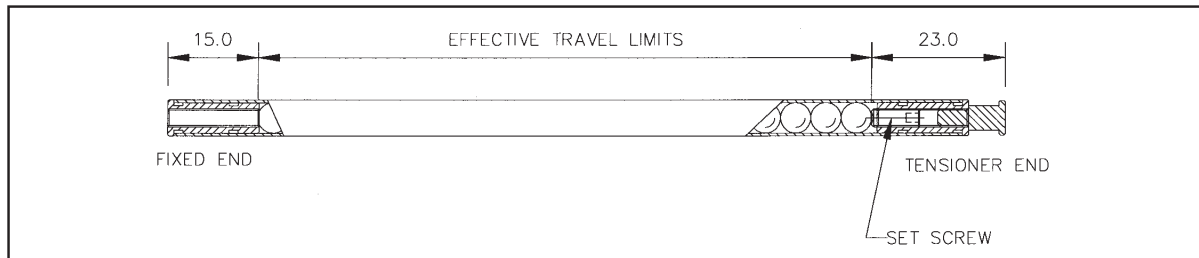

Figure 6.7 - The MHG Scale

NOTES:

- (A) Erroneous readings will occur if the MHG Reader Head is allowed to travel beyond Effective Travel Limits. (Refer to Figure 6.7)
- (B) The pre-load on the balls are factory set via the set screw at the tensioner end. Do not tamper with or adjust the set screw as this will alter the calibration and accuracy specification of the scale and void the warranty.
- (C) When mounting scales in the vertical plane the tensioner end should be positioned at the top.

Mounting the Scale

The scale support brackets kit consists of the Anchor Pin, Support Pin, Support Link, and Pillar(s). (Refer to Figure 5.8) In order to avoid the risk of damage to the scale during installation all MHG Linear Encoders include a set up bar. The set up bar is of the same diameter as the MHG Scale and will be used to align the brackets to the Reader Head.

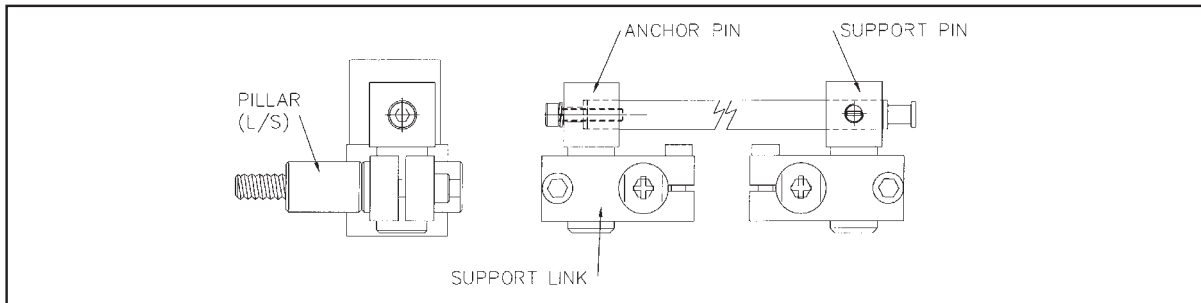

Figure 6.8 - MHG Scale Support Bracket

Traverse the machine to its maximum position toward the non-cable entry side of the Reader Head. Maximum position means all available travel, including hand winding past any electrical limits or trip dogs.

Carefully slide the MHG Scale set-up bar through the Reader Head, allowing for sufficient scale to project from the Reader Head in order to fit the scale support brackets.

Assemble the support link to the anchor pin leaving approximately 3mm (1/8") gap between the bottom of the anchor shoulder and the top of the link.

Slide the link/anchor assembly onto the scale set-up bar to approximately 5mm (0.2") away from the end of the Reader Head.

Transfer punch through the support link and into the machine casting. It is important that the support link be kept square to its mounting surface at all times.

Remove the link/anchor assembly and the scale set-up bar from the Reader Head. Drill and tap M6 x 12mm deep hole (USA 1/4 - 20 x 1/2") into the machine casting as marked by the transfer punch. Fit the pillar(s) to the machine casting by using one of the methods shown in Figure 6.3. The pillar shoulder fits square and flush to the machine surface.

A maximum of two support pillars may be screwed together to allow for sufficient adjustment of the scale. If two pillars are insufficient to enable the scale to be mounted, then additional brackets will be necessary. These brackets must be sufficiently rigid to eliminate any axial movement of the scale.

Loosely fit the support link/anchor assembly onto the pillar and pass the scale set-up bar through the Reader Head and into the anchor pin. While gently sliding the scale set-up bar in and out of the anchor pin, carefully tighten the cap screws on the support link, ensuring that the scale set-up bar slides smoothly through the Reader Head and into the anchor pin. If any interference is detected then fully loosen the cap screws on the support link and repeat this step.

Remove the scale set-up bar from the Reader Head and traverse the machine to its full extent in the opposite direction. Full extent means hand winding past electrical limits.

Assemble the scale support link to the support pin leaving approximately 3mm (1/8") gap between the bottom of the mounting shoulder and the top of the link. (Refer to Figure 6.8)

Slide the link/pin assembly onto the scale set-up bar making certain that there is sufficient clearance between the Reader Head and the support link to prevent damage to the Reader Head cable. Do not secure the support pin to the scale at this time.

Transfer punch through the support link and into the machine casting. It is important that the support link be kept square to its mounting surface at all times.

Remove the link/pin assembly and the scale from the Reader Head. Drill and tap M6 x 12mm deep (USA 1/4 - 20 x 1/2 deep) into the machine casting as marked by the transfer punch. Fit the pillar(s) to the machine casting by using one of the methods shown in Figure 6.3. The pillar shoulder fit square and flush to the machine surface.

Loosely fit the support link/pin assembly onto the pillar and pass the scale set-up bar through the Reader Head and into the support pin. While gently sliding the set-up bar forward and back 25 - 50mm (1" - 2") through the support mounting, carefully tighten the screws on the support link, ensuring that the scale set-up bar slides smoothly through the Reader Head and into the support pin. If any interference is detected then fully loosen the screws on the support link and repeat this step.

IMPORTANT WARNING

THE CENTRE LINE BORE OF THE READER HEAD MUST BE IN DIRECT ALIGNMENT WITH THE CENTRE LINE BORE OF THE SUPPORT PIN. PERMANENT DAMAGE TO SCALE AND/OR ERRONEOUS READER WILL OCCUR IF THIS WARNING IS NOT FOLLOWED. REFER TO FIGURE 6.9

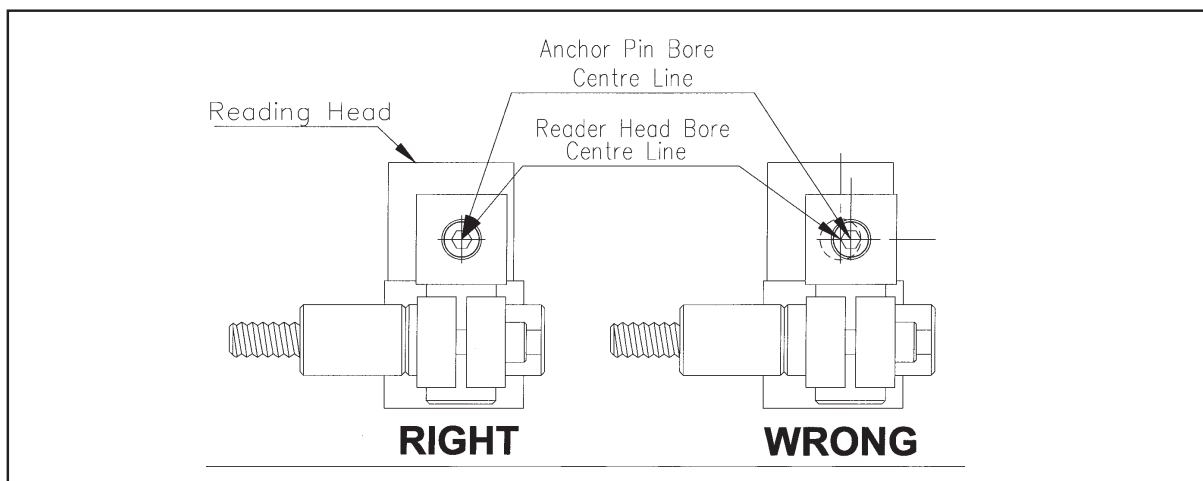

Figure 6.9 - Reader Head and Bracket Alignment

Carefully slide the MHG Scale through the support pin, ensuring the fixed end is inserted first, through the Reader Head and into the anchor pin.

Using the M3 x 16 skt cap screw and spring washer, secure the scale to the anchor pin. It is **important** that the nylon set screw on the support pin be only "pinched" to the scale at the tensioner end. **DO NOT OVER TIGHTEN THE NYLON SET SCREW ON THE SUPPORT PIN.**

6.2.1 Single End Mounting

For installations requiring a lower profile assembly, there is an alternative method for fixing the scale at one end only by way of the single end mounting block assembly (Refer to Figure 6.10). The MHG single end mounting kit is sold separately, as for UK part number 600-65340, US part number LBK02 (for SHG & MHG) and LBK03 (for MHG only).

Note: The maximum total length of scale not exceed 450mm (18") when using the single end mounting block.

Once the Reader Head has been installed slide the scale through the head and insert the fixed end of the scale into the single end mounting block. (Refer to Figure 6.10)

Once the position for the single end mounting block has been determined mark the machine casting with the slot in the block. Drill and tap a M5 x 12mm deep hole. Fit the bracket using the M5 skt head cap screw and washer. Check the alignment by gently sliding the scale through the head and in and out of the mounting block, adjustments may be carried out by altering the M3 jacking screws. When the alignment is complete secure the scale by inserting the M3 screw and spring washer through the mounting block and into the fixed end of the scale.

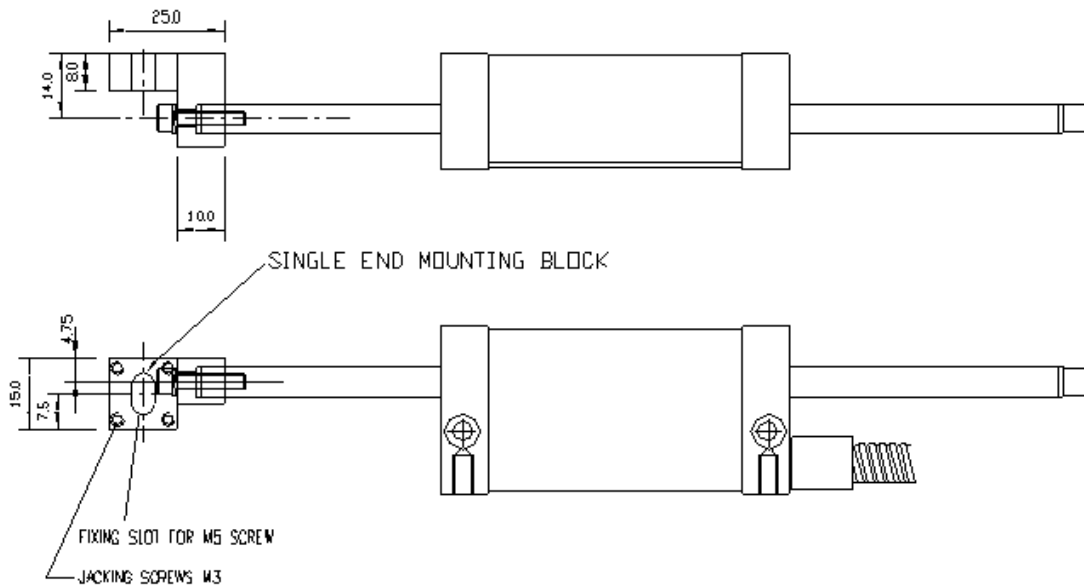

Figure 6.10 - MHG Single End Mounting

7.0 FITTING THE SCALE GUARD

Each Encoder includes a protective guard. This aluminium guard is intended to protect the scale from impact damage. The guard can be attached to the machine casting or by means of the scale support pillars. (Refer to Figure 7.1)

To fit the guard to the support pillars, measure and mark off the distance between the centre of each pillar. For SHG drill two 8.5mm (3/8"), for MHG 7mm (9/32") holes at either end of the guard. The guard can be attached to the pillars by using the button head screws provided. After the guard is attached, move the machine axis to both extents of its travel ensuring that the guard does not interfere with or rub against the Reader Head.

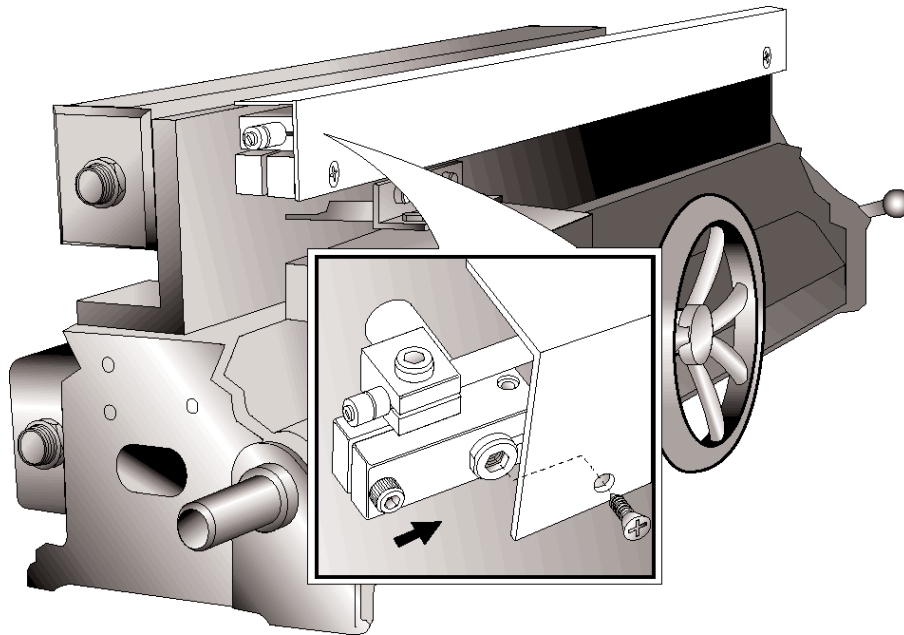

Figure 7.1 - Fitting the Scale Guard (example shown using a SHG Scale)

8.0 CABLE ROUTING

The most important and the most over looked aspect of fitting the Encoder is proper cable routing. Dangling and loose cables can be snagged or broken causing irreparable damage. Care should be taken in order to ensure that the cables are secured to the machine and that cable loops do not interfere with any part of the machine or the Encoder movements. "P" clips and thread forming screws are provided to route the cables from the Reader Head to the digital readout unit.

Note: The armoured cable is an integral part of the Reader Head. If the cable becomes damaged, then it would have to be replaced complete with the Reader Head.

If extension cables are used, do not allow the plug and socket junction to lie in the swarf tray or in the direct flow of coolant or oil.

In order to avoid problems associated with electrical noise and interference, do not allow the cables to lie across electrical motors, fuse boxes or electrical pumps.

9.0 FINAL CHECK

Prior to putting the Encoder into operation, slowly traverse the machine axis to both extents of its travel checking at all times that the cables are secure and that machine over travel cannot occur. Newall will not accept responsibility for Encoder malfunction caused by over travel or damaged cables.

Appendix A - SHG

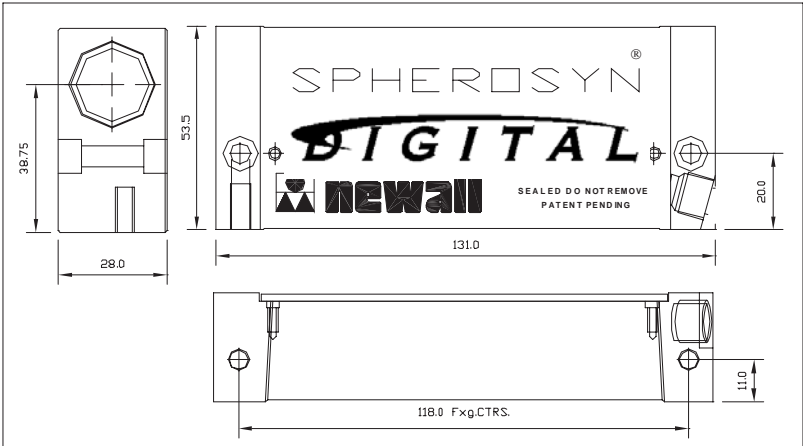
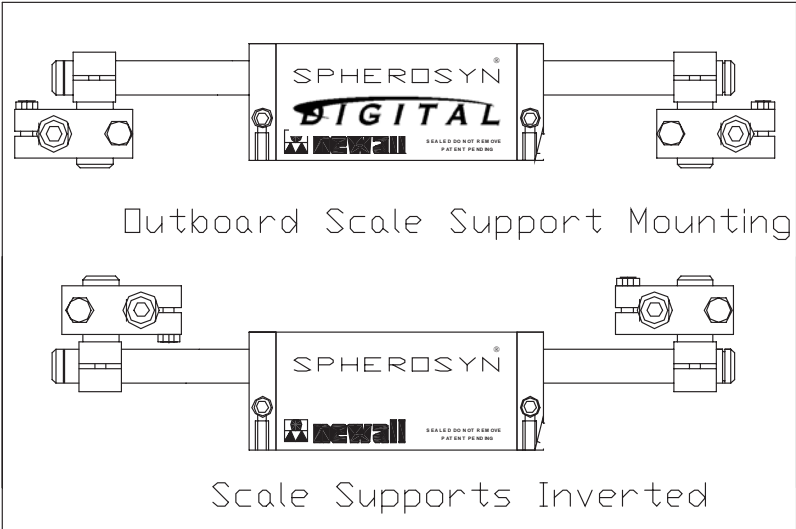

Appendix A - MHG

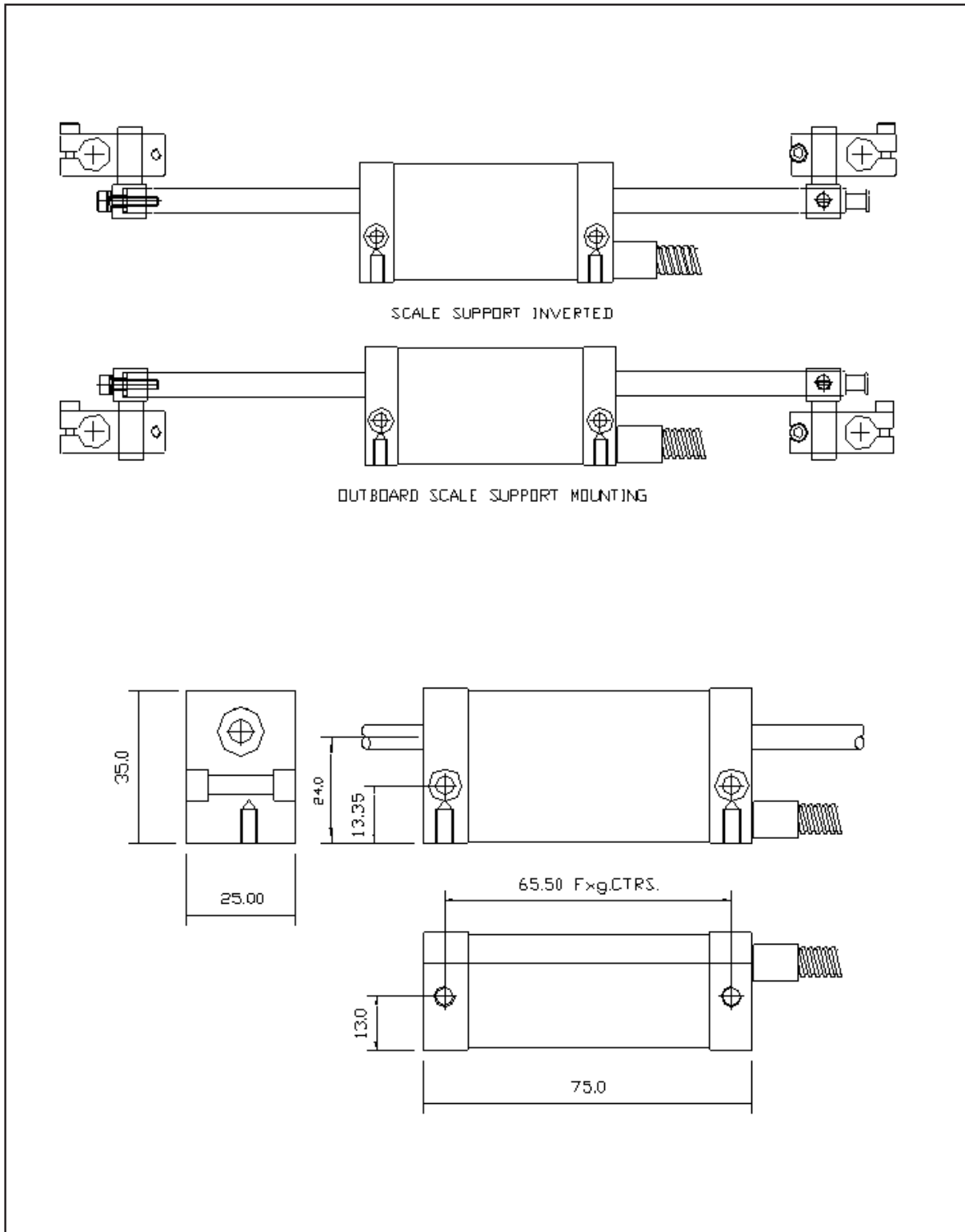

NEWALL MEASUREMENT SYSTEMS LTD

HEAD OFFICE

Newall Measurement Systems Ltd.

Technology Gateway, Cornwall Road

South Wigston

Leicester LE18 4XH

United Kingdom

Telephone: +44 (0)116 264 2730

Facsimile: +44 (0)116 264 2731

Email: sales@newall.co.uk

Web: www.newall.co.uk

Newall Electronics, Inc.

1778 Dividend Drive

Columbus, OH 43228

Telephone: +1 614 771 0213

Toll Free: 800.229.4376

Facsimile: +1 614 771 0219

Email: sales@newall.com

Web: www.newall.com